



Specialists in **3D profiling**

Build more, fabricate
smarter

RPC 1200
Beam cutting machine

> hgg-group.com

The RPC 1200 does it all

4 Sided box section cutting

with 360° laser scan to provide real-time material deviation data and done in only 2 cuts to save on ignition time and have the ability to cut bevelled corners.

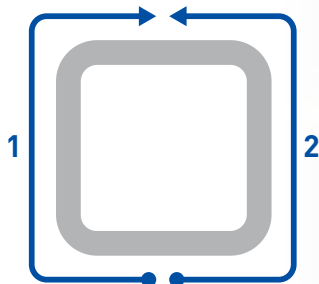

Perfectly straight holes

produced with arc shape and divergence compensation, variable speed and plasma current to deliver gouge free holes and extended consumable lifetime.

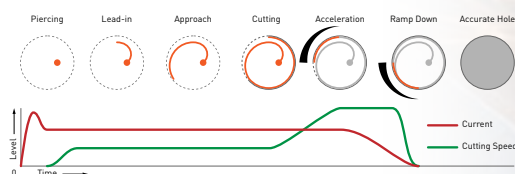

Plate cutting

that utilizes the capabilities and footprint of the same machine to produce fully nested add-on parts.



3000x1200 mm

4-Sided marking

of contours and text, directly extracted from the 3D model to save over 30% in fit-up time.

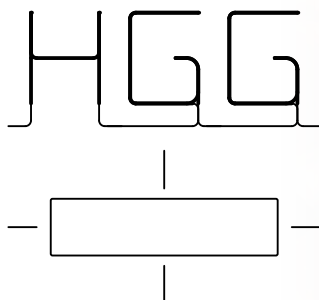



Bolted + welded connections

without
compromises



> Fabricate Faster

**Build
More**

> Be More Accurate

**No More
Rework**

> Work Smarter

**Freedom
to Design**

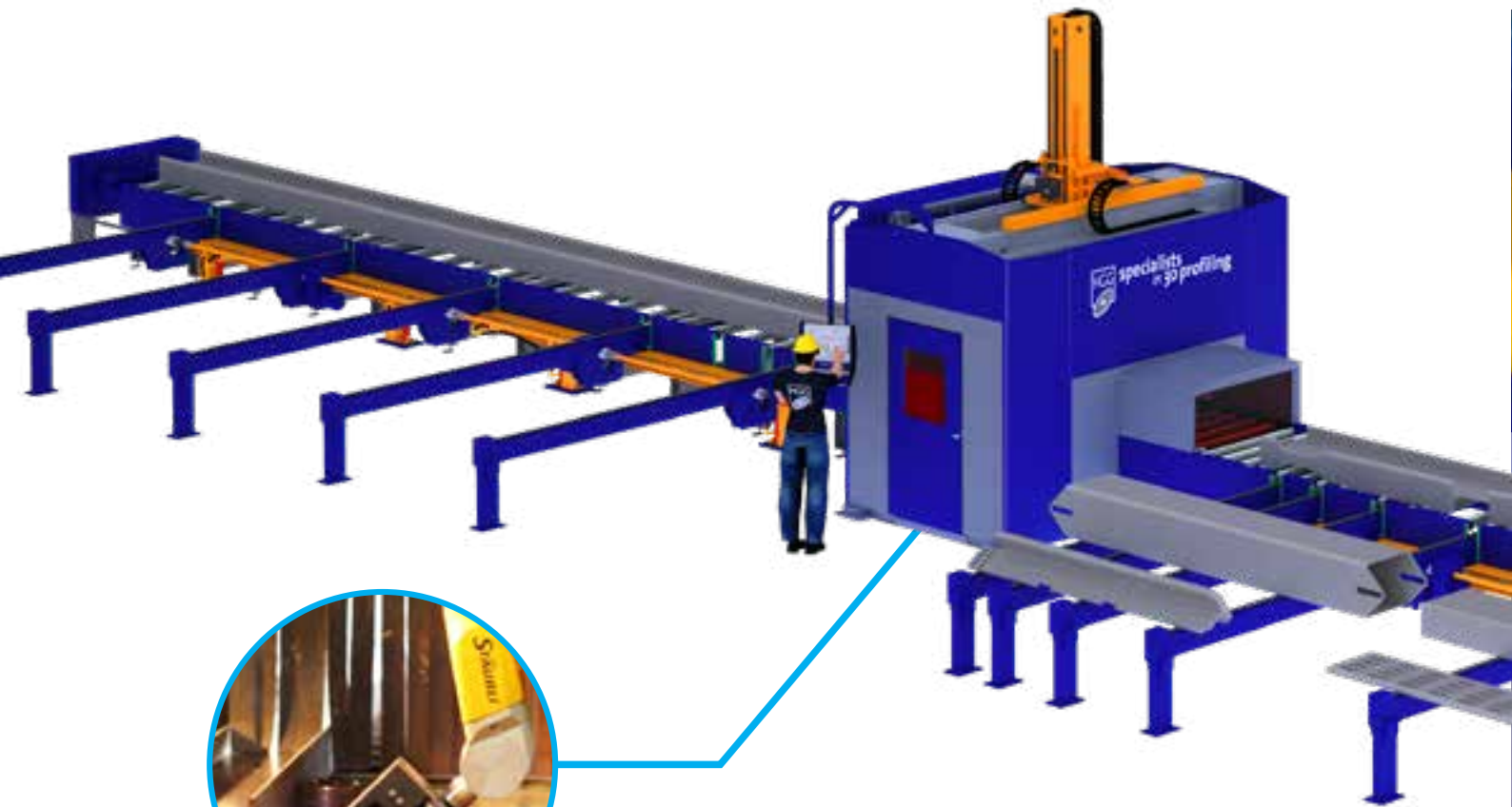

‘Our robot experience provides the freedom to cut without compromises.’



100×50 – 1220×430 mm
[4"×2" – 48"×17"]

100×100 – 600×400 mm
[4"×4" – 23"×16"]

100×50 – 475×150 mm
[4"×2" – 18½"×6"]

75×75 – 300×300 mm
[3"×3" – 12"×12"]

100×50 – 140×140 mm
[4"×2" – 5½"×5½"]

Beam Cutting 2.0

The RPC 1200 Beam Cutting Machine is a plasma cutting machine, developed to cut beams for both bolted and welded connections. It is the most advanced and productive beam cutting machine on the market today. The RPC sets a new standard by offering an entire fab shop in a single machine.

‘A complete
fab shop in one
machine’



100×50 – 200×100 mm
[4"×2" – 8"×4"]



100×50 – 140×140 mm
[4"×2" – 5½"×5½"]



100×50 – 140×140 mm
[4"×2" – 5½"×5½"]



50×50 – 3000×1220 mm
[2"×2" – 118"×48"]
Plate



max. 12 Ton
max. 26 400 lbs

**‘We tripled our
revenue within
the first 3 months’**

Build More

HGG uses cutting routines that make you fabricate faster by reducing the amount of ignitions and creating a new part with every single cut. Using our High Speed Plasma Technology, ready-to-fit parts come off the machine, prepared for the desired connection; both bolted and welded.



‘In comparison to many traditional machines, the RPC actually finishes the cuts, which makes us more competitive and saves the fabricator precious time’

Mr. Gerrit Teunissen
Branch Manager
SQS Southern Steel

The RPC 1200 reaches deeper than any other machine to cut ratholes without rework

Produced with no rework required!

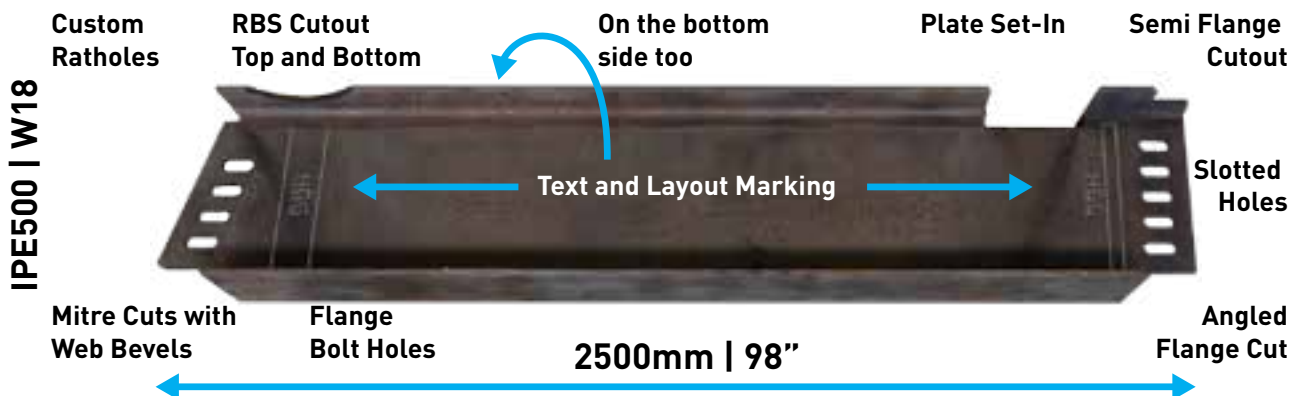

Build More

Production speed is always an important factor. By improving the quality of difficult cuts the RPC 1200 saves time in the cutting process and the grinding process.



MANUAL DURATION (H:MM:SS) [ESTIMATED]	Example Beam: 3x 3992 mm / 13' 1 1/8"	DURATION ON RPC 1200 [SIMULATED] (H:MM:SS)
0:01:30	Initialization	0:00:30
0:45:00	Measurements	0:05:51
2:05:00	Cuts	0:23:10
0:00:00	Markings	0:00:00
0:02:00	Part removal	0:01:42
0:02:00	Rest removal	0:00:33
2:55:30	Total duration	0:31:48
0:09:00	Grinding	0:00:20





High speed plasma and excellent cutting intelligence

'The RPC's cutting intelligence is impressive. We saved a lot of time in production, fitting and welding.'



G specialists
in 3D profiling
www.hgg-group.com

F

➤ Be More Accurate

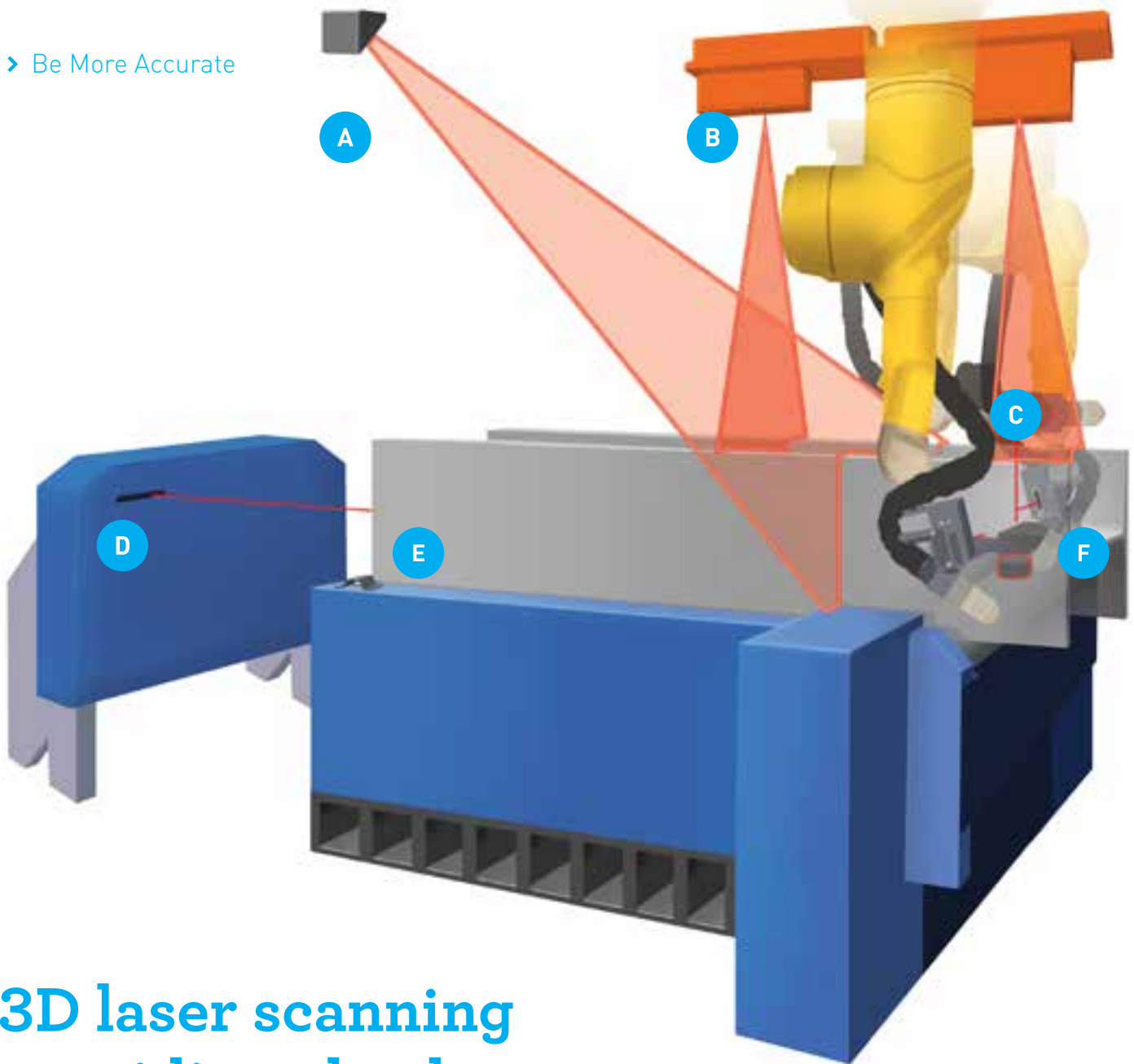

3D laser scanning providing absolute accuracy

A Initialisation Laser to indicate the starting position

B Double scan Laser to measure profile deviation

C Torch Laser to measure deviation from programmed profile

D Length Measurement Laser to determine position and length

E Light Indicator to detect profiles

F Measurement Roll to measure width

The RPC 1200 automatically compensates for positional displacement, torsion and section distortions

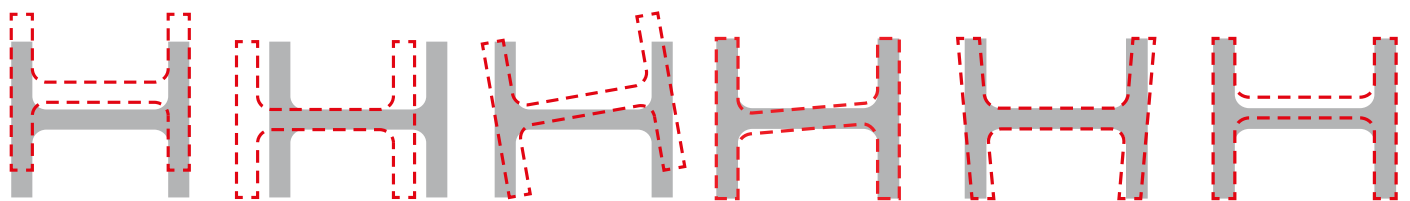

1. Sagittal offset 2. Transversal offset 3. Torsion
The RPC 1200 compensates for positional displacement and torsion with every scan.

1. Slanted web 2. Trapezium flange 3. Off-center web
The RPC 1200 compensates for section distortions per beam. Every beam only needs one scan for path correction.

No More Rework

Accurate measurement is of fundamental importance to minimize rework and decrease overall processing time. HGG's real-time laser measurement, unique cutting sequences and subsequent compensations provide finished parts that are ready-to-fit.

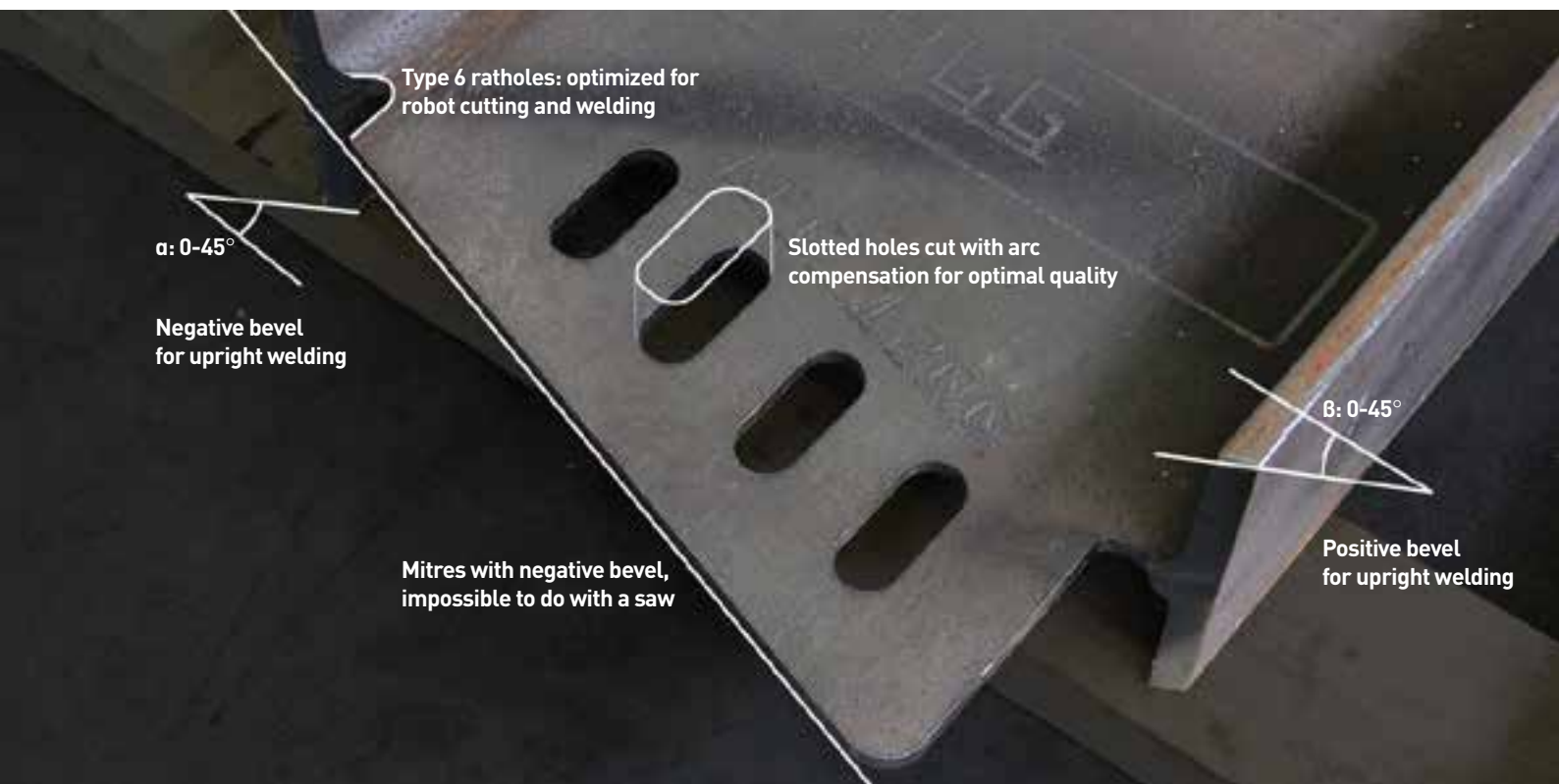

No more probing! HGG's laser measurement technology does away with material deviations

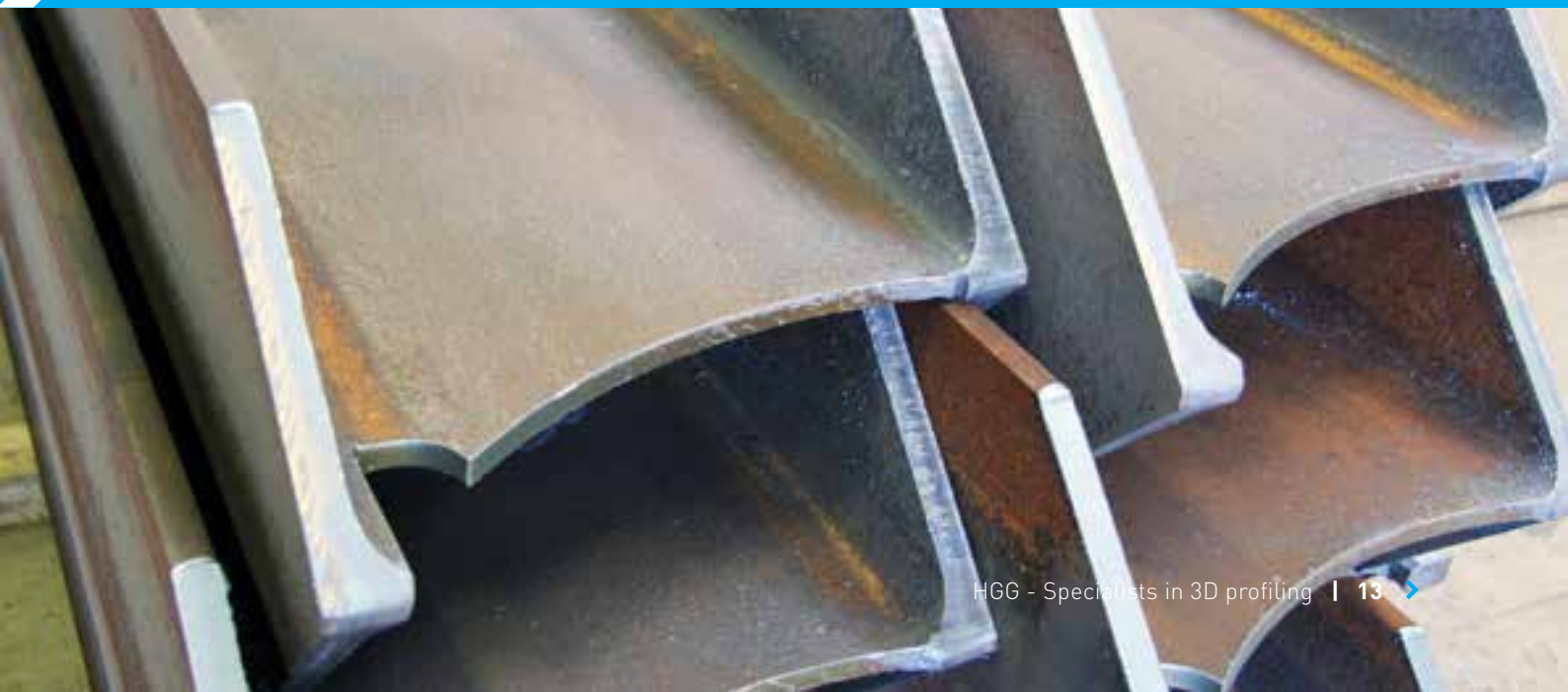

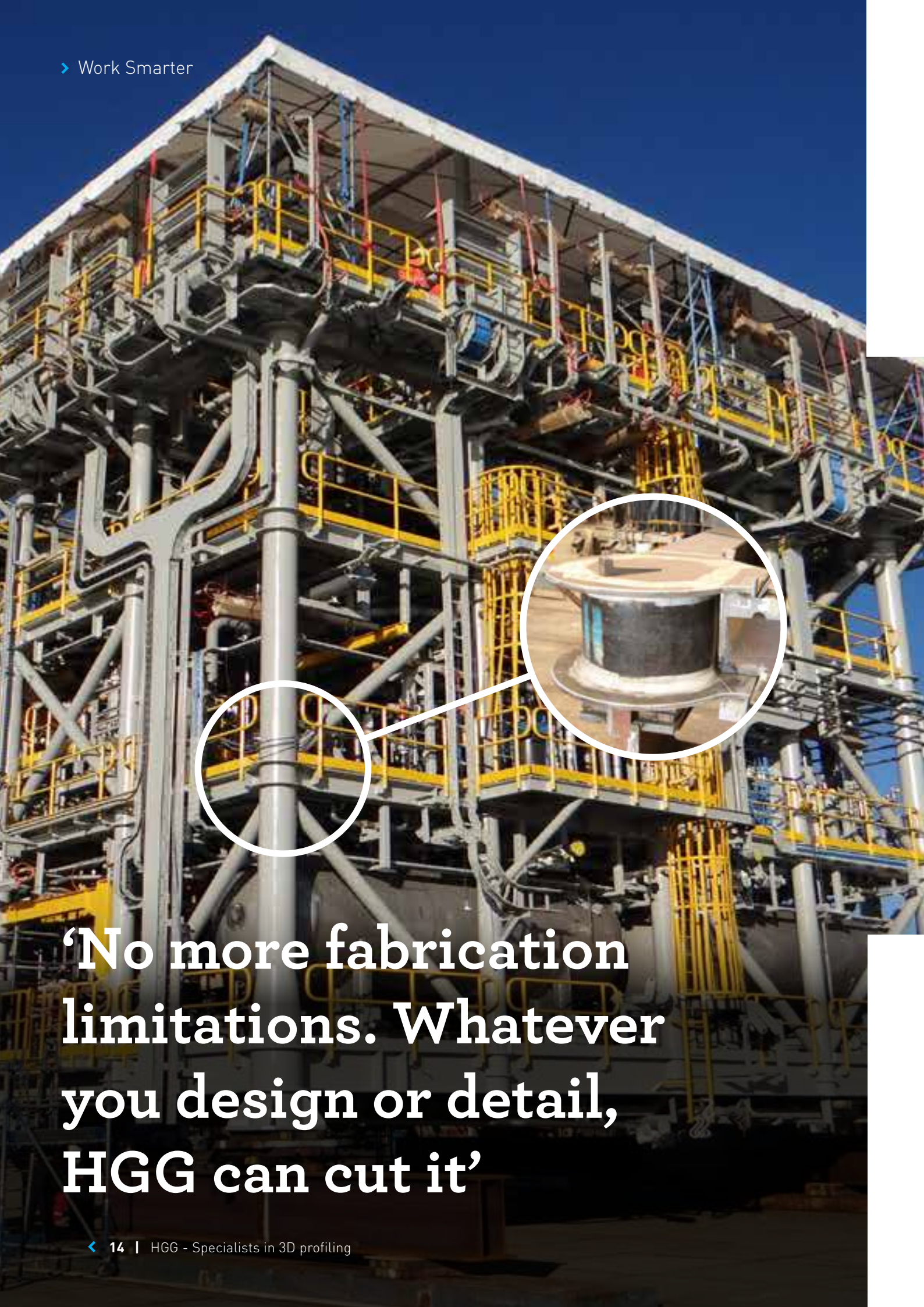

‘No more fabrication limitations. Whatever you design or detail, HGG can cut it’

Freedom to Design

In the past a structure was designed and detailed based upon the capabilities of conventional steel processing equipment. Fast forward to today, limitations are something from the past and we provide the ultimate freedom to design!

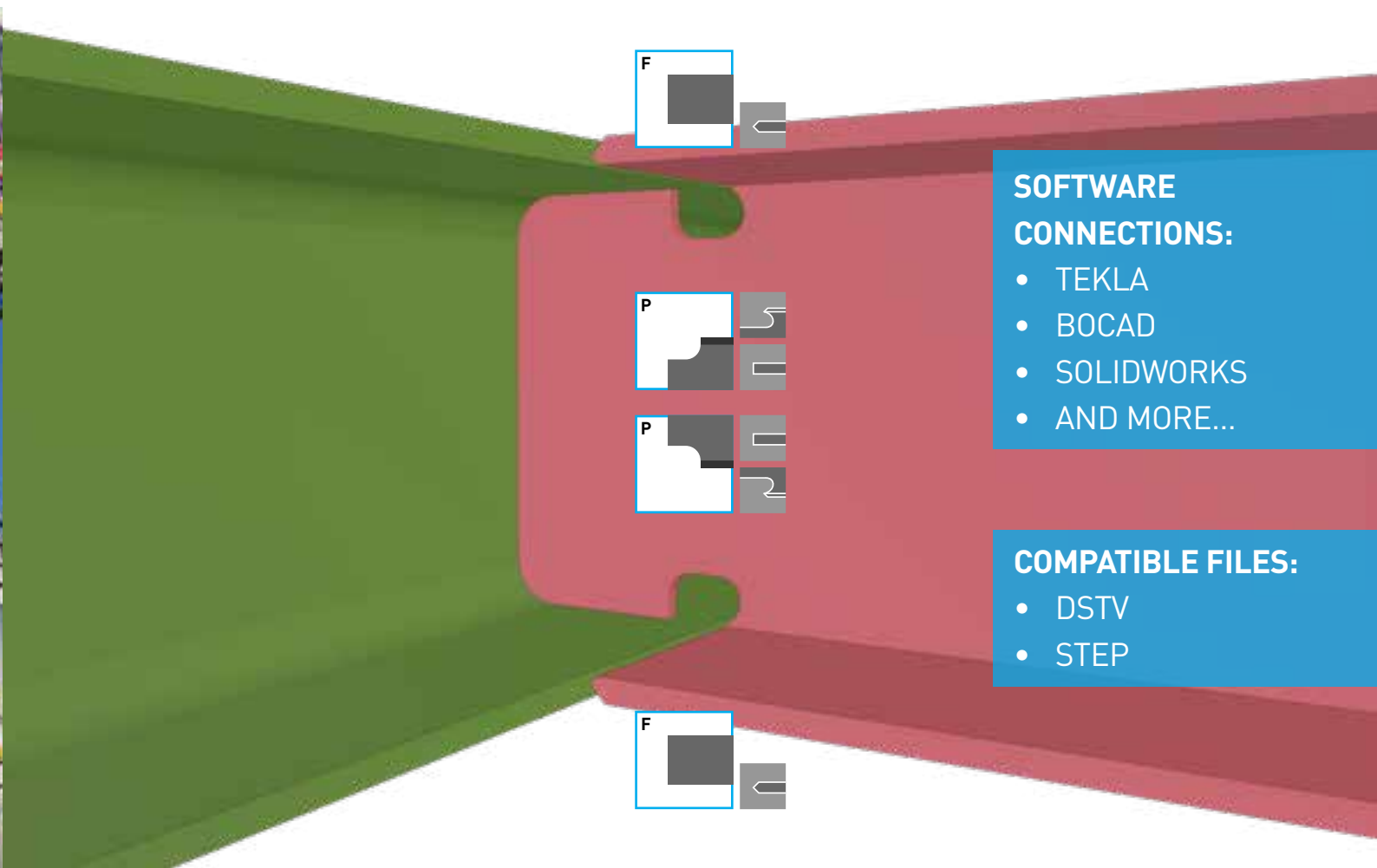

- SOFTWARE CONNECTIONS:**
- TEKLA
 - BOCAD
 - SOLIDWORKS
 - AND MORE...

- COMPATIBLE FILES:**
- DSTV
 - STEP



‘HGG’s software interprets the shape from a CAD model directly, removing machine limitations or the need to re-design due to machine incapacibilities.’

Mr. Frits Boekee
QC Engineer
Hollandia Offshore



**Accurate cuts
are paramount
to a faster
process.**

'They know your industry, application and production process. That makes HGG unique!'



A large industrial manufacturing facility, likely a metalworking shop. The scene is dominated by green machinery, including a large central machine with a yellow control panel and a conveyor system. The floor is covered with metal beams and pipes. The background shows a high ceiling with exposed steel trusses and corrugated metal walls. The lighting is bright, highlighting the industrial environment.

**‘Automation is the future
that gives us the edge in a
competitive market.’**

Freedom to Design

While industry 4.0 is the next big thing, HGG connects the RPC 1200 with other companies up- and downstream. Kaltenbach and Peddinghaus, two of the biggest companies in the steel fabrication world, trust HGG for their robotic plasma cutting process.



‘The automation of the future requires seamless integration of machines and software. We are able to seamlessly integrate the RPC in our fabrication lines.’

Mr. Stefan Stiegeler
Sales Engineer
Kaltenbach GmbH.

WE USE THE MACHINES OURSELVES!

During the training we explain how to optimize CAD, prepare parts for export/cutting and configure machine settings and use your fabrication parts as examples.

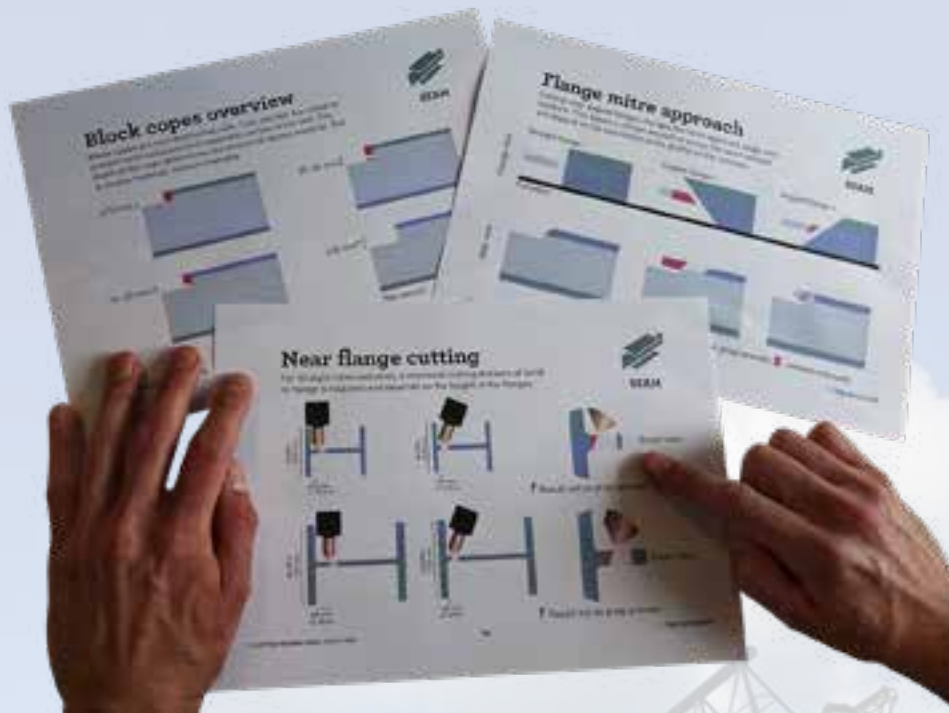

eXperience
CENTER



Experience Center

In cooperation with HGG Profiling Contractors where we run daily production on the machines ourselves, we provide training for new and existing customers where they learn about work preparation and operating profiling machines from people with over 20 years of experience.



‘We always strive for the best way to let our customers benefit from our knowledge. Get trained by our experts and become an expert yourself!’



Mr. Jos Wijnker
General Manager
HGG Profiling Services



‘You’ll find our **150+** robots
in every corner of the world’

Freedom

FOR THE WORLD OF STEEL



HGG International BV

Zuidrak 2
1771 SW Wieringerwerf
The Netherlands

CONTACT US FOR MORE INFORMATION

☎ (+31) 227 50 40 30
✉ info@hgg-group.com
🌐 hgg-group.com

FOLLOW HGG



HGG INDIA, AFRICA & MIDDLE EAST

T: (+91) 770 2055 222 / (+971) 55 8077 643
E: HGGME@HGG-GROUP.COM

HGG RUSSIA

T: (+7) 921 355 98 95
E: MSM@HGG-GROUP.COM

HGG AMERICAS

T: (+1) 330 461 6855 / (+1) 832 592 3858
E: AMERICAS@HGG-GROUP.COM

HGG ASIA PACIFIC

T: (+86) 136 8163 2558
E: ASIAPACIFIC@HGG-GROUP.COM

HGG CHINA

T: (+86) 136 8163 2558
E: HGGCHINA@HGG-GROUP.COM

HGG EUROPE

T: (+31) 227 50 40 30
E: SALES@HGG-GROUP.COM